

Type 2RK SSI



- Absolute Encoder - Ø 58 mm
- Shaft - ø ¼ inch to ø 10 mm
- Singleturn or Multiturn
- SSI Interface
- Binary or Gray Code
- Preset of Zero Position
- Choice of Counting Direction
- Enclosure Rating IP 65 or IP 67
- Supply voltage 5V or 9-30 V

Electrical Specifications	
Encoder Type:	Absolute Multiturn
Singleturn Resolution:	13 bits (8192) steps pr. revolution
Number of Revolutions:	12 bits (4096) revolutions 16 bits (65536) revolutions 20 bits (1048576) revolutions 24 bits (16777216) revolutions
Supply Voltage:	5 VDC ±5% or 9-30 VDC
Typical Current Consumption:	30 mA @ V _{sup} = 5V 25 mA @ V _{sup} = 10V 15 mA @ V _{sup} = 24V
Accuracy:	± 0,35°
Interface:	SSI (Synchronous Serial Interface)
Output Code:	Binary or Gray
Electrical Interface:	Differential (RS422)
Clock Frequency:	100 kHz to 2 MHz
Counting Direction:	Increasing clockwise or increasing counter clockwise seen from shaft end of encoder
Electrical Protection:	Reverse polarity and output short circuit protected
Noise Immunity:	Tested to EN61000-6-2 : 2005 (industrial environments) Electromagnetic compatibility (EMC) and EN 61000-6-3 : 2007 (residential, commercial, and light-industrial environments) for Electromagnetic compatibility (EMC)

Mechanical Specifications	
Material:	Housing: Aluminum Cap: Aluminum Shaft: Stainless steel AISI 303
Weight:	Encoder: ~ 190 gr (6,7 oz) Cable: 60 gr / meter (2,12 oz / meter)
Bearing Life:	> 1,9 x 10 ¹⁰ revolutions at rated load
Shaft Speed:	4.500 rpm (max. sustained) IP 65 3.000 rpm (max. sustained) IP 66 / IP 67
Starting Torque:	< 0,02 Nm (2,83 oz-in) at 25° C
Mass Moment of Inertia:	6,0 gcm ² (8,5 x 10 ⁻⁵ oz-in-sec ²)
Shaft Loads:	Axial: 150 N (33,75 lbs) max. Radial: 250 N (56 lbs) max.

Environmental Specifications	
Operating Temp.:	-40° to +85° C
Storage Temp.:	-40° to +85° C
Shock:	100 G @ 11 ms
Vibration:	10 G @ 10-2000 Hz
Bump:	10 G @ 16 ms (1000 x 3 axis)
Humidity:	98 % RH without condensation
IP Rating:	IP 65 / Nema 5 (approx.) IP 67 / Nema 6 (approx.) option

Connection Options	
Cable:	8 leads (0,14 mm ² , 26 AWG) twisted pairs; shielded
Connector:	8-pin M12

Mechanical Dimensions

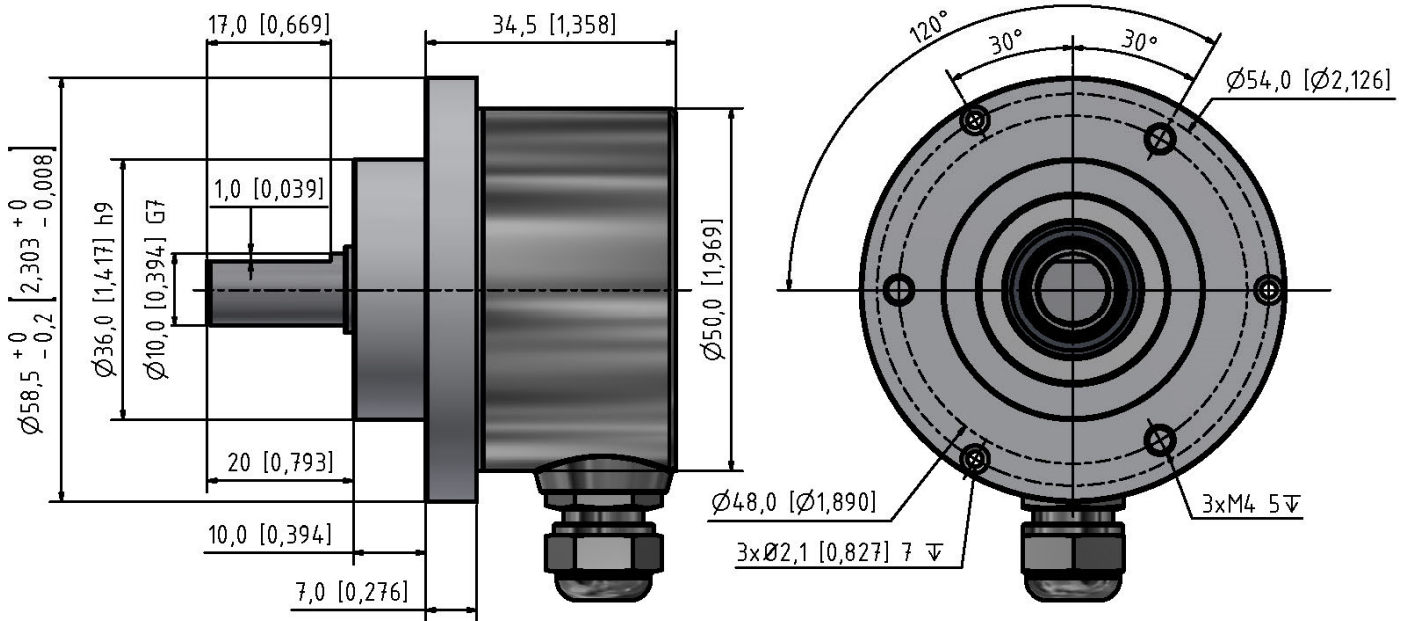

Standard Cable Gland (axial or radial outlet) mm [inches]

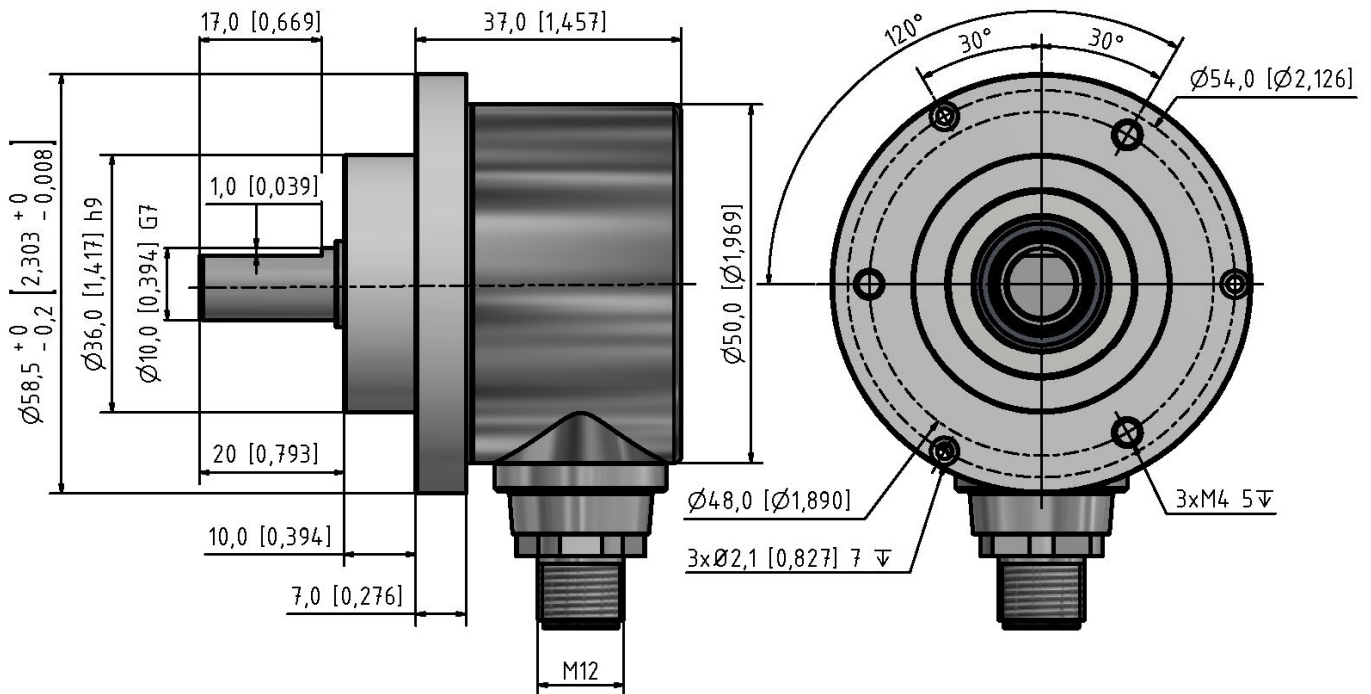

M12 Connector

mm [inches]

Output Terminations

Cable

Differential Input/output

Signal	Wire Color
CLK+	Green
CLK-	Yellow
DO+	Gray
DO-	Pink
Direction	Red
Preset	Blue
Vsup	Brown
GND	White

Shield connected to case ground

M12 Connector

Differential Input/output

Pin Number	Signal
1	GND
2	Vsup
3	CLK+
4	CLK-
5	DO+
6	DO-
7	Preset
8	Direction

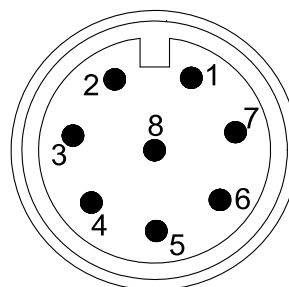

*Shield must be connected to
connector housing*

SSI Interface Timing

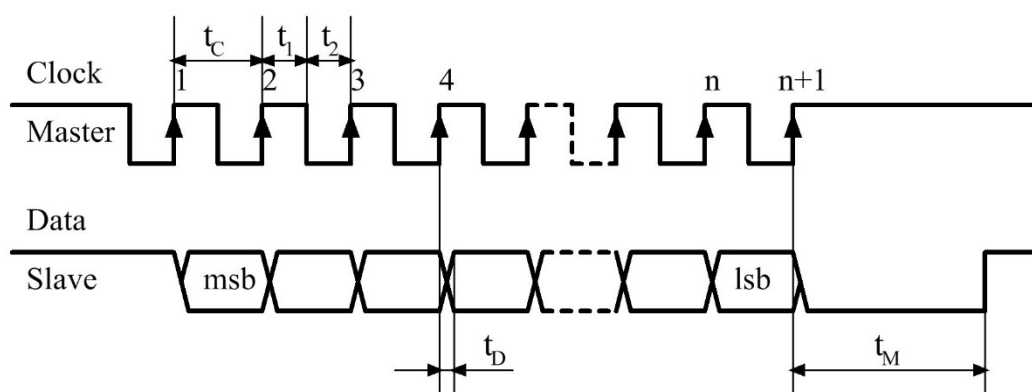

msb = Most Significant Bit

lsb = Least Significant Bit

n = Total Number of Bits

t_c = Clock Period = 0,5 to 10 μ Sec (100kHz to 2 MHz)

t_1 = Clock High = 50% \pm 15% of Clock Period

t_2 = Clock Low = 50% \pm 15% of Clock Period

t_D = Clock to Data Valid = Max. 100 nSec

t_M = Monoflop Time = 20 \pm 3 μ Sec

Implementation

During the initial set-up and installation of the encoder, it is possible to set the direction of rotation and preset the encoder to zero.

Setting of Direction.

The connection designated "Direction" is used to set the direction of rotation. Notice, that the encoder must not be powered when the direction of rotation is set/changed. Notice also, that the encoder will change its position value when the direction of rotation is changed. Direction of rotation is viewed on the shaft end of the encoder.

Voltage Level on Input	Function
High: V_{sup} or $V_{sup}/2 \leq V_{in} \leq V_{sup}$	Encoder Increasing on Counter Clockwise Rotation
Low: Input not connected or $0V \leq V_{in} \leq V_{sup}/2$	Encoder Increasing on Clockwise Rotation

Preset to Zero

The connection designated "Preset" is used to preset the encoder to zero. Notice, that the encoder must be powered when it is preset to zero.

Voltage Level on Input	Function
High: V_{sup} or $V_{sup}/2 \leq V_{in} \leq V_{sup}$	Encoder Value is set to Zero
Low: Input not connected or $0V \leq V_{in} \leq V_{sup}/2$	Inactive

The encoder will be held at zero as long as the line is high, even though the shaft is turned. The line must be high for at least 100 mSec. for the preset to take effect. The new zero point will be stored permanently in the encoder.

Ordering Code

Example: 2RK-1SS – 1213 – 9 – B – D – 10 – 20 – 65 – 01 – S – 00

2RK-1SS - - - - **D** - - **20** - - - **S** -

1 2 3 4 5 6 7 8 9 10

1. Resolution

Singleturn
 Resolution 13 bits **0013**
Multiturn
 Revolutions 12 bits **1213**
 Revolutions 16 bits **1613**
 Revolutions 20 bits **2013**
 Revolutions 24 bits **2413**

2. Supply Voltage

5 VDC..... **5**
 9-30 VDC..... **9**

3. Code

Binary **B**
 Gray **G**

4. Electrical Interface

Differential (RS422).....**D**

5 & 6. Shaft diameter

1/4" mm x 20 mm
 8 mm x 20 mm
 3/8" mm x 20 mm
 10 mm x 20 mm

5. 6.

1/4 x **20**
08 x **20**
 3/8 x **20**
10 x **20**

7. IP Rating

IP 65 **65**
 IP 67 **67**

8. Cable Length

Standard cable is 1m..... **01**
 Specify length..... **XX**
 No cable..... **00**

9. Cable & Connector Takeout

Side radial..... **S**
 Back axial**B***
 *Only encoders with cable

10. Connector

M12 8-pin **P8***
 No Connector..... **00**
 *Only side (radial) takeout