



Type SCH68SUB SSI

- Absolute Encoder - Ø 68 mm [2.68"]
- Hollow bore Ø 10 mm to Ø 1 inch
- Singleturn or Multiturn
- SSI Interface
- Binary or Gray Code
- Preset of Zero Position
- Choice of Counting Direction
- Enclosure Rating IP 65 or IP 67
- Supply voltage 5V or 9-30 V

Electrical Specifications

Encoder Type:	Absolute Multiturn
Singleturn Resolution:	13 bits (8192) steps pr. revolution
Number of Revolutions:	12 bits (4096) revolutions 16 bits (65536) revolutions 20 bits (1048576) revolutions 24 bits (16777216) revolutions
Supply Voltage:	5 VDC ±5% or 9-30 VDC
Typical Current Consumption:	30 mA @ Vsup = 5V 25 mA @ Vsup = 10V 15 mA @ Vsup = 24V
Accuracy:	± 0,35°
Interface:	SSI (Synchronous Serial Interface)
Output Code:	Binary or Gray
Electrical Interface:	Differential (RS422)
Clock Frequency:	100 kHz to 2 MHz
Counting Direction:	Increasing clockwise or increasing counter clockwise seen from shaft end of encoder
Electrical Protection:	Reverse polarity and output short circuit protected
Noise Immunity:	Tested to EN61000-6-2: 2005 (industrial environments) Electromagnetic compatibility (EMC) and EN 61000-6-3: 2007 (residential, commercial, and light-industrial environments) for Electromagnetic compatibility (EMC)

Mechanical Specifications

Material:	Housing: AISI 316L Cap: AISI 316L Hollow Shaft: AISI 316L
Weight:	Encoder: Approx. 2200 g (77.601 oz)
Bearing Life:	> 1.9 x 10 ¹⁰ revolutions at rated load
Shaft Speed:	2000 rpm max.
Starting Torque:	< 0.05 Nm (7.08 oz-in) at 25° C IP 68
Mass Moment of Inertia:	1400 gcm ² (19,82 x 10 ⁻⁸ oz-in-sec ²)
Shaft Loads:	Axial 100 N (22.50 lbs) max. Radial 100 N (22.50 lbs) max.

Environmental Specifications

Operating Temperature:	-10° to +50° C
Storage Temperature:	-10° to +50° C
Shock:	100 G @ 11 ms
Vibration:	10 G @ 10-2000 Hz
Bump:	10 G @ 16 ms (1000 x 3 axis)
Enclosure Rating:	IP 68 / Permanent submersion to 6000 m

Connection Options

Connectors:	SUBCON 8pin male MCBH8MSS
--------------------	---------------------------

Mechanical Dimensions

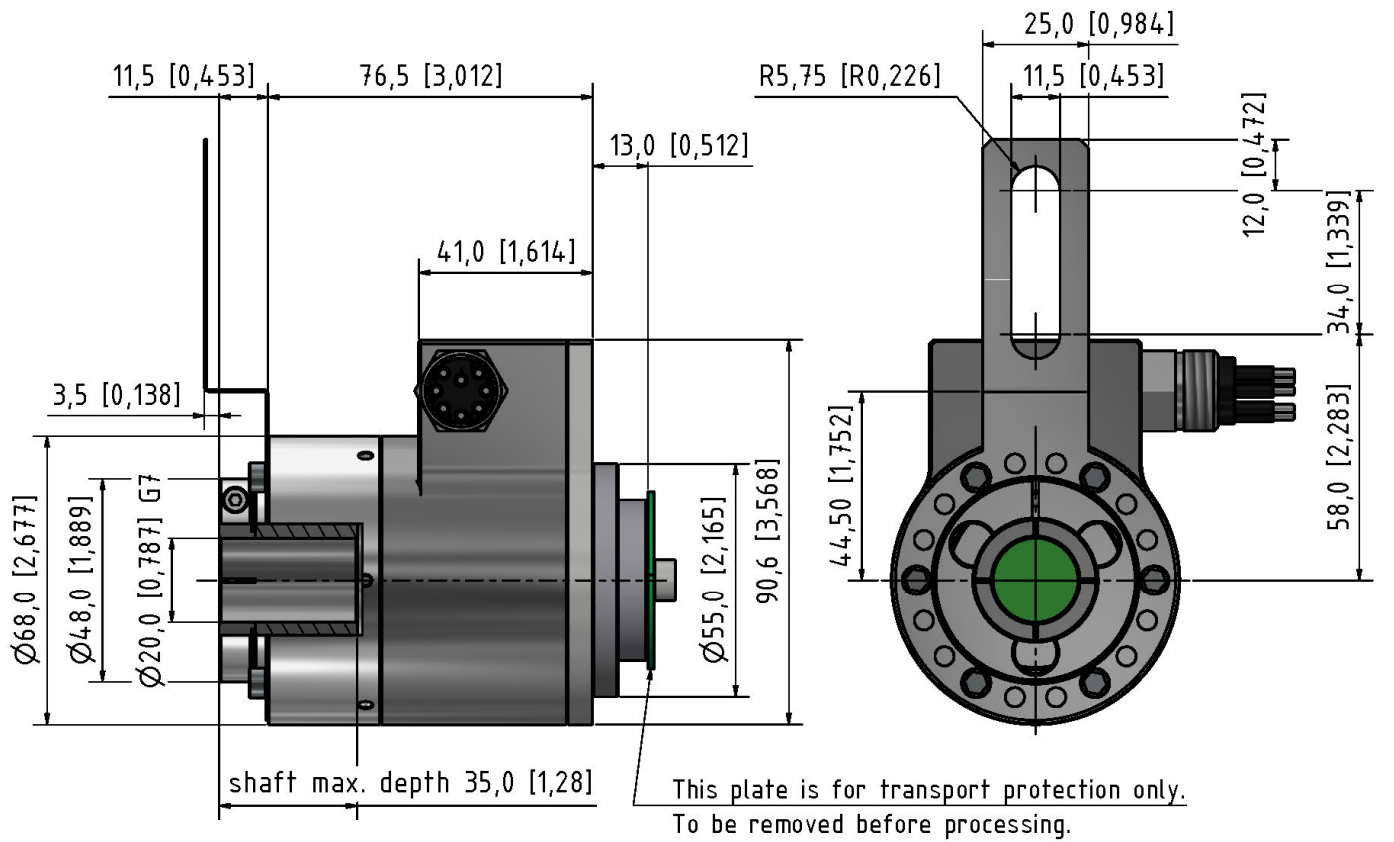

mm [inches]

Output Terminations – Connector:

SUBCON 8 Pin	
Differential Input/Output	
Pin Number	Signal
1	GND
2	Vsup
3	CLK+
4	CLK-
5	DO+
6	DO-
7	Preset
8	Direction

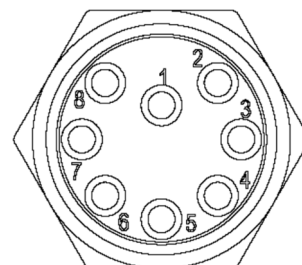

SSI Interface Timing

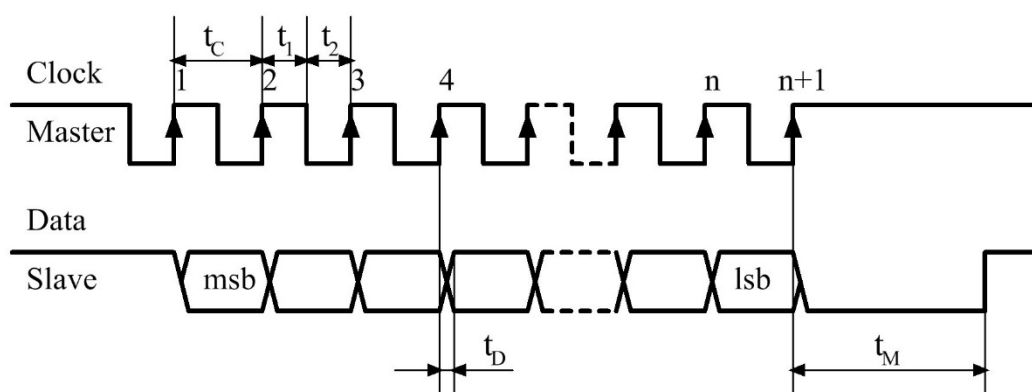

msb = Most Significant Bit

lsb = Least Significant Bit

n = Total Number of Bits

t_c = Clock Period = 0,5 to 10 μ Sec (100kHz to 2 MHz)

t_1 = Clock High = 50% \pm 15% of Clock Period

t_2 = Clock Low = 50% \pm 15% of Clock Period

t_D = Clock to Data Valid = Max. 100 nSec

t_M = Monoflop Time = 20 \pm 3 μ Sec

Implementation

During the initial set-up and installation of the encoder, it is possible to set the direction of rotation and preset the encoder to zero.

Setting of Direction.

The connection designated "Direction" is used to set the direction of rotation. Notice, that the encoder must not be powered when the direction of rotation is set/changed. Notice also, that the encoder will change its position value when the direction of rotation is changed. Direction of rotation is viewed on the shaft end of the encoder.

Voltage Level on Input	Function
High: V_{sup} or $V_{sup}/2 \leq V_{in} \leq V_{sup}$	Encoder Increasing on Counter Clockwise Rotation
Low: Input not connected or $0V \leq V_{in} \leq V_{sup}/2$	Encoder Increasing on Clockwise Rotation

Preset to Zero

The connection designated "Preset" is used to preset the encoder to zero. Notice, that the encoder must be powered when it is preset to zero.

Voltage Level on Input	Function
High: V_{sup} or $V_{sup}/2 \leq V_{in} \leq V_{sup}$	Encoder Value is set to Zero
Low: Input not connected or $0V \leq V_{in} \leq V_{sup}/2$	Inactive

The encoder will be held at zero as long as the line is high, even though the shaft is turned. The line must be high for at least 100 mSec. for the preset to take effect. The new zero point will be stored permanently in the encoder.

Ordering Code

Example: SCH68SUB-1SS – 1213 – 9 – B – D – 20 – 35 – 68 – 00 – S – C8-S1

SCH68SUB-1SS - - - - - - - - - - -

1 2 3 4 5 6 7 8 9 10 11

1. Resolution

Singleturn
 Resolution 13 bits **0013**

Multiturn
 Revolutions 12 bits **1213**
 Revolutions 16 bits **1613**
 Revolutions 20 bits **2013**
 Revolutions 24 bits **2413**

2. Supply Voltage

5 VDC..... **5**
 9-30 VDC..... **9**

3. Code

Binary **B**
 Gray **G**

4. Electrical Interface

Differential (RS422)..... **D**

5. & 6. Hollow Shaft (diameter)

20 mm x 35 mm
3/4 inch (19,05 mm) x 35 mm

5 6

20 x 35
3/4 x 35

*Other hollow shaft diameters
 may be requested*

7. IP Rating

IP 68 **68**

8. Cable Length

No Cable **00**

9. Cable Takeout

Side (Standard) **S**

10. Connector

SUBCONN 8 **C8**

*Female Mating Connector
 is not included*

11. Spring Coupling

1 hole p/n 80131017 **S1**
 2 holes p/n 80131067..... **S2**
 1 hole p/n 80132464 **S3**
 2 holes p/n 80131062 **S4**

See Accessories data sheet for Anti-rotation Springs/Torque Arm options